

CHARIOT S/E HYDRAULIQUE V2

GAGGENAU

CONCEPT

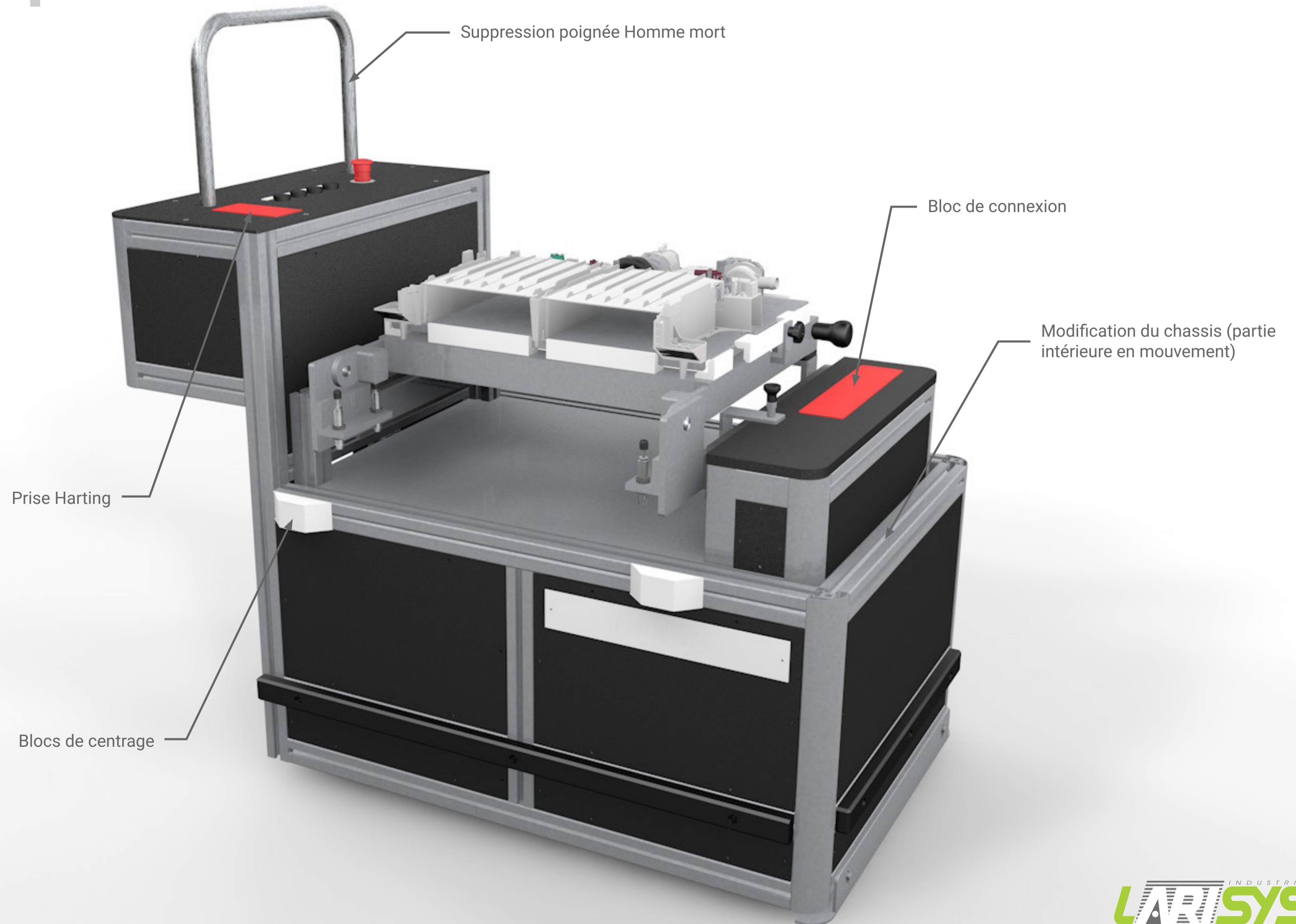

CONCEPT

Réduction maximum de la longueur du chariot = 2500 mm hors tout

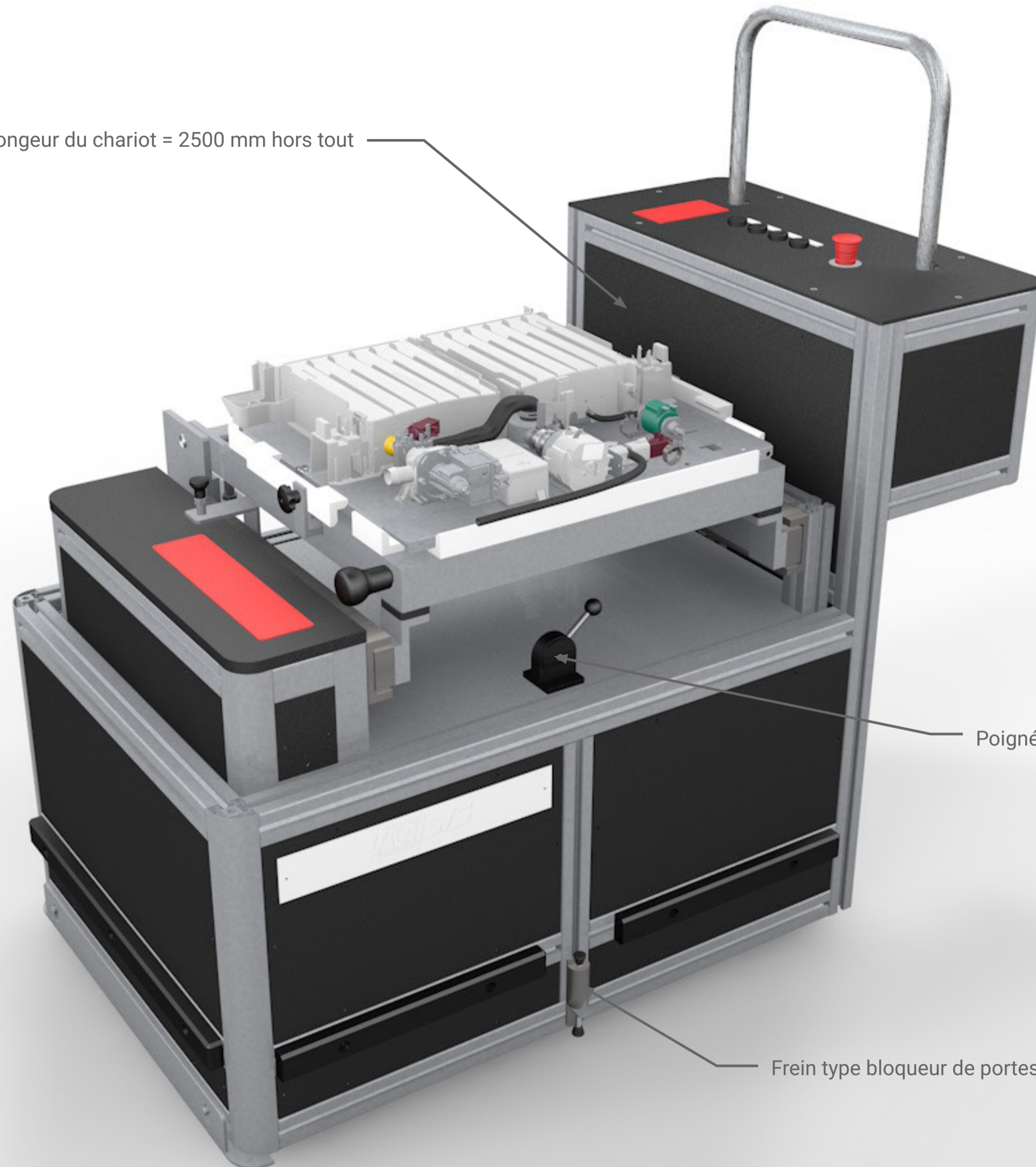

Poignée de contrôle rotation roues centrales

Frein type bloqueur de portes

CONCEPT

Position de déchargement

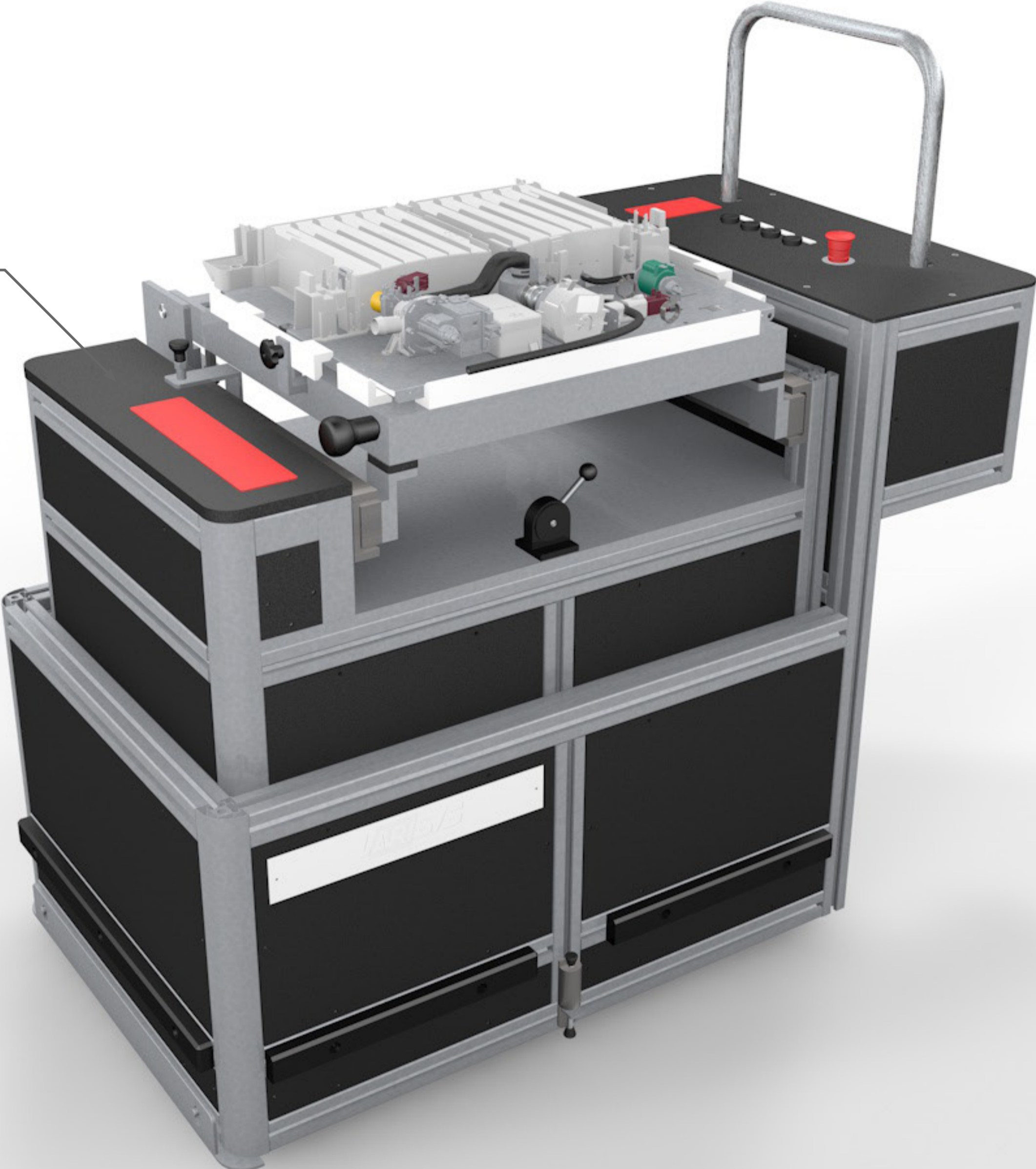

CONCEPT

Réceptacle de centrage

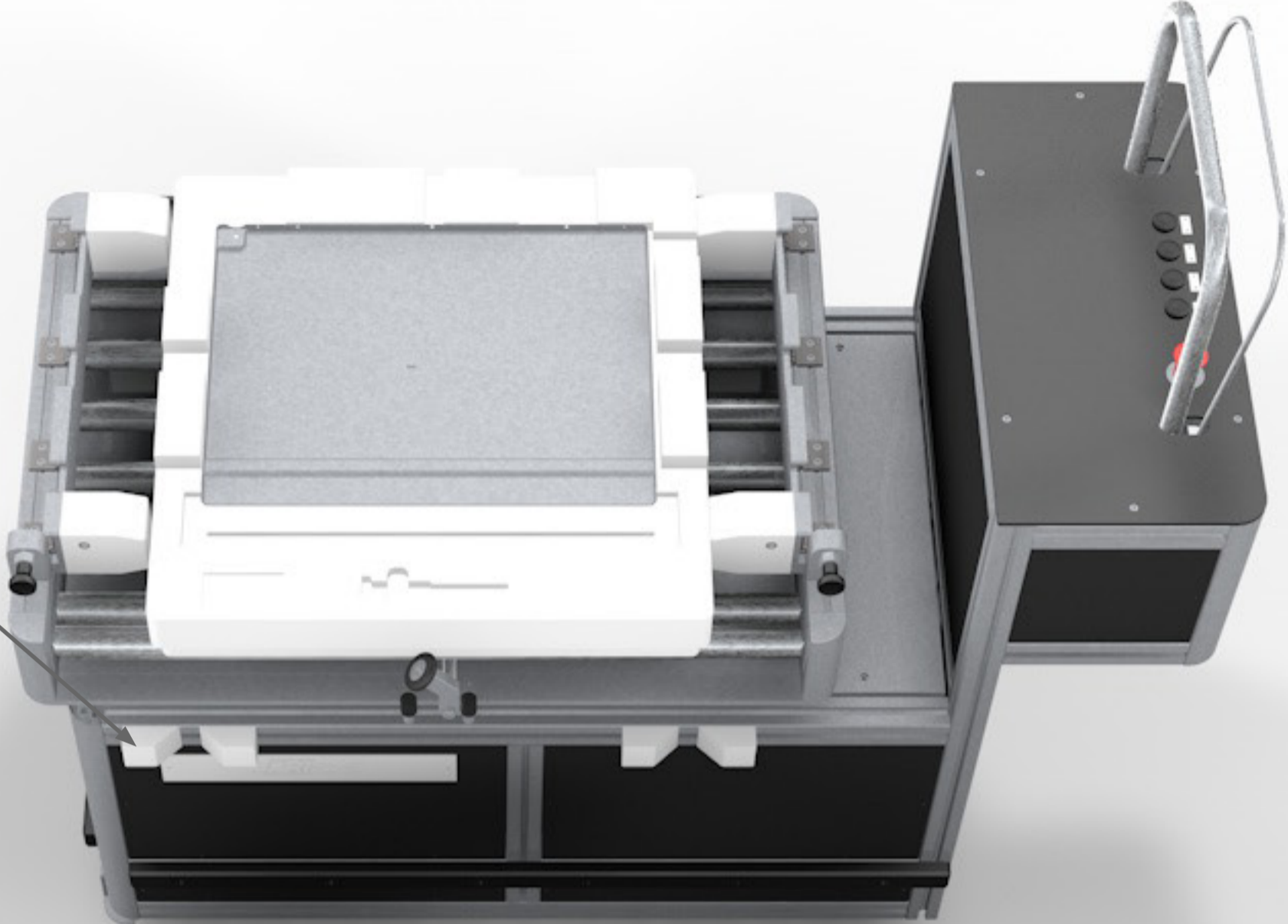

Système de blocage en rotation X2

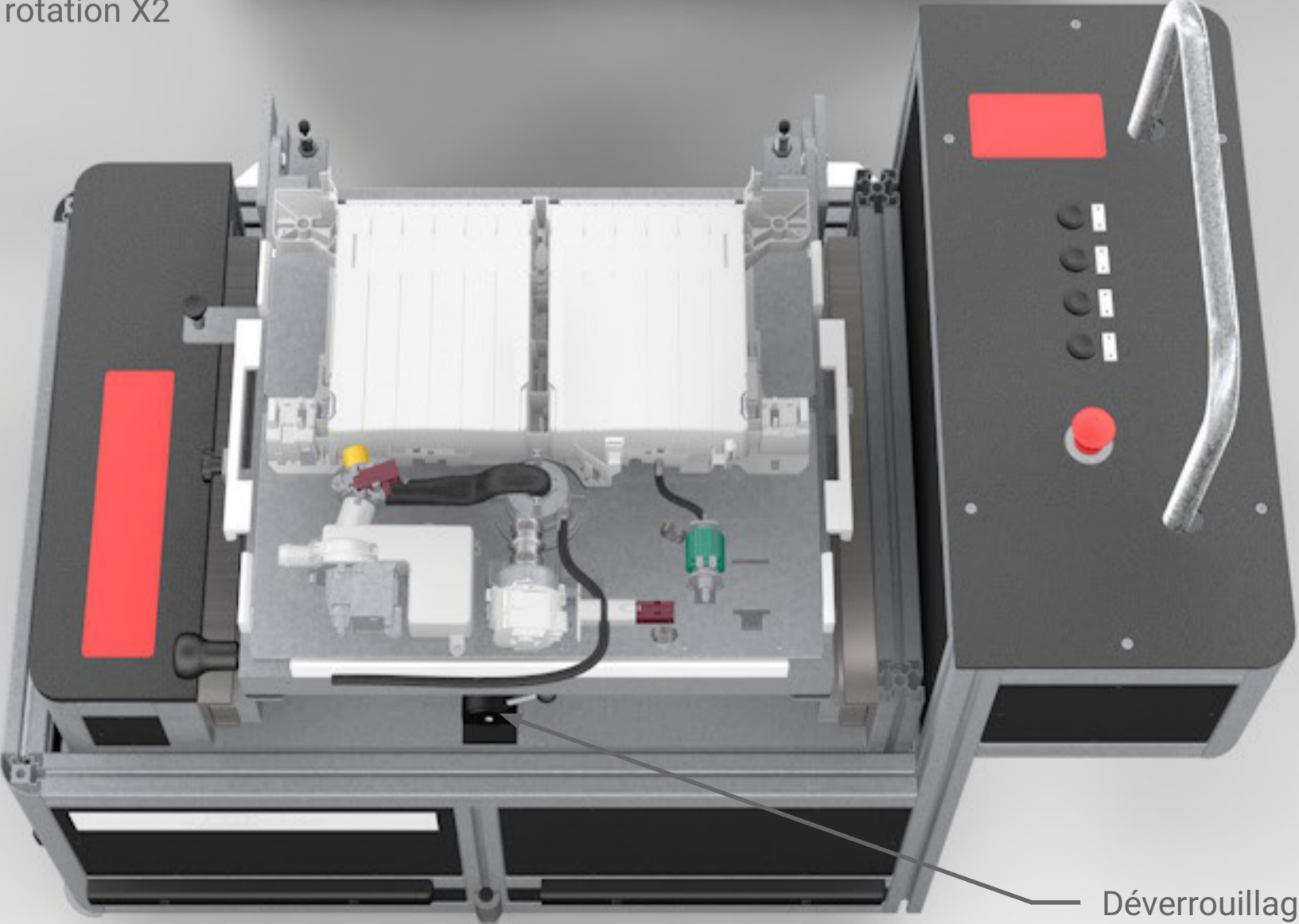
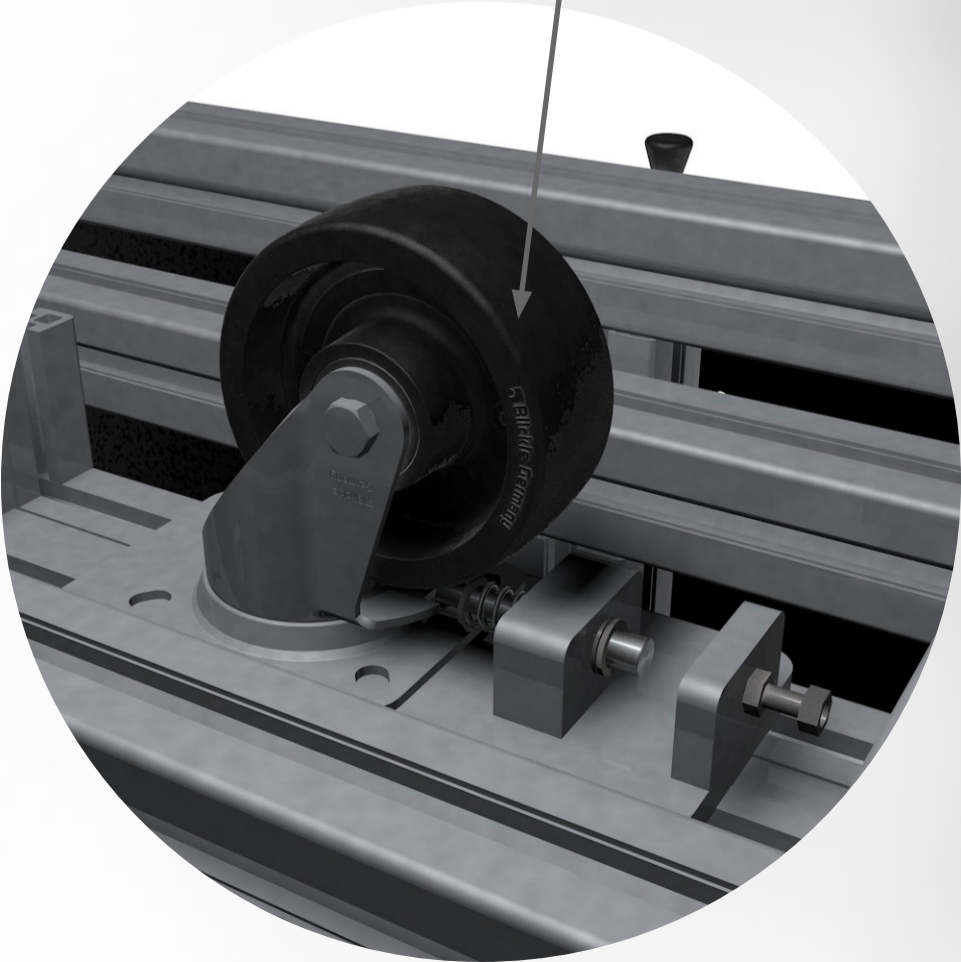

Déverrouillage

CONCEPT

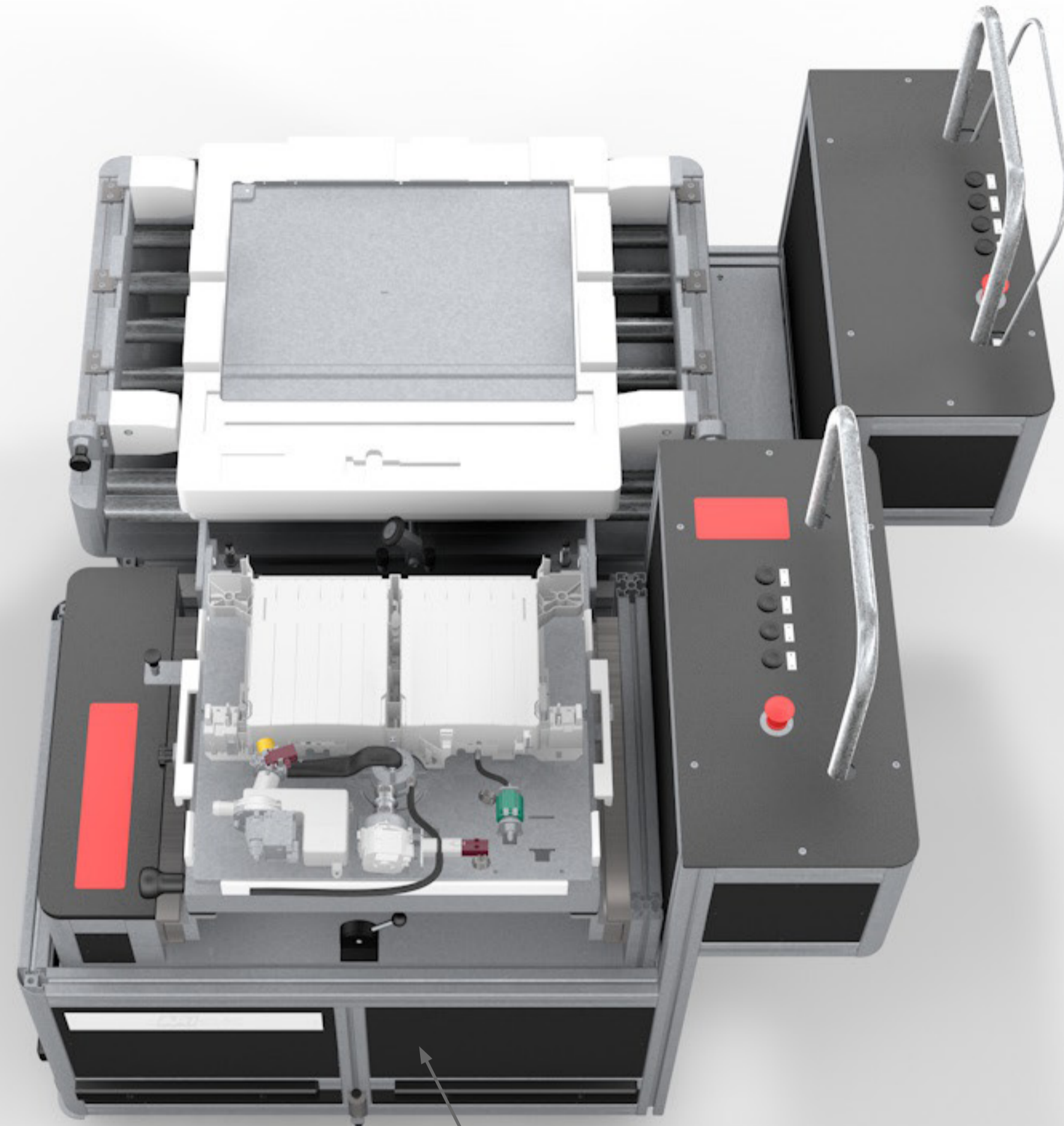
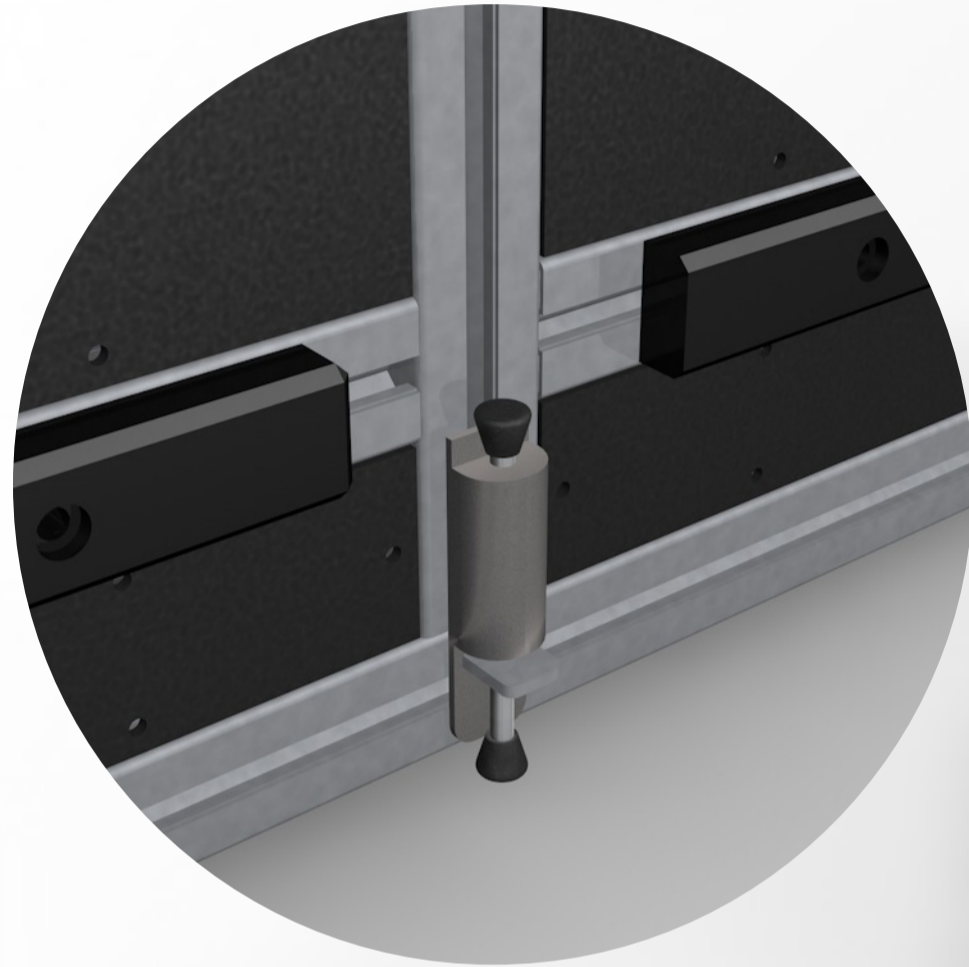

Mise en contact des deux chariots et verrouillage

CONCEPT

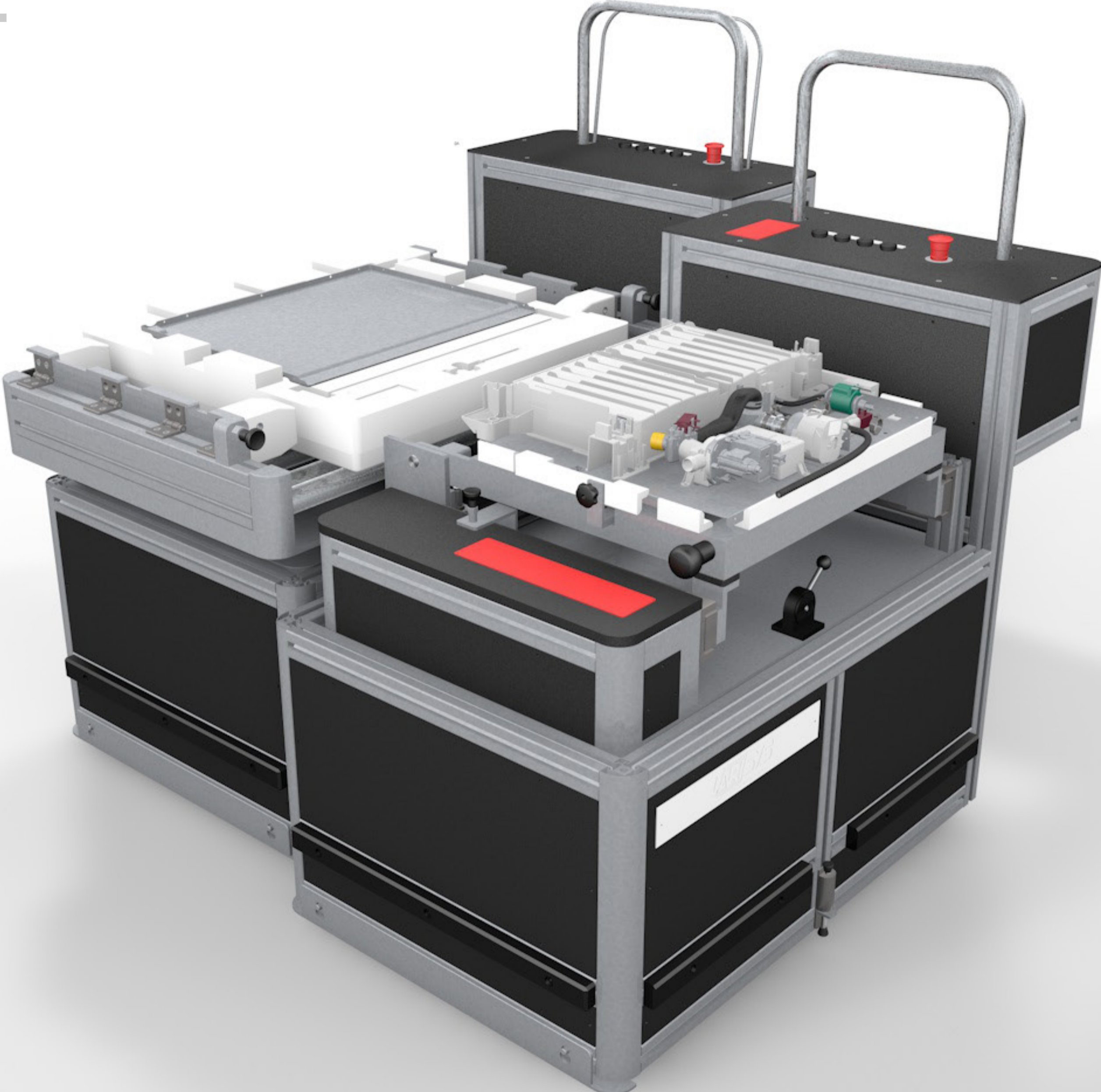

CONCEPT



CONCEPT

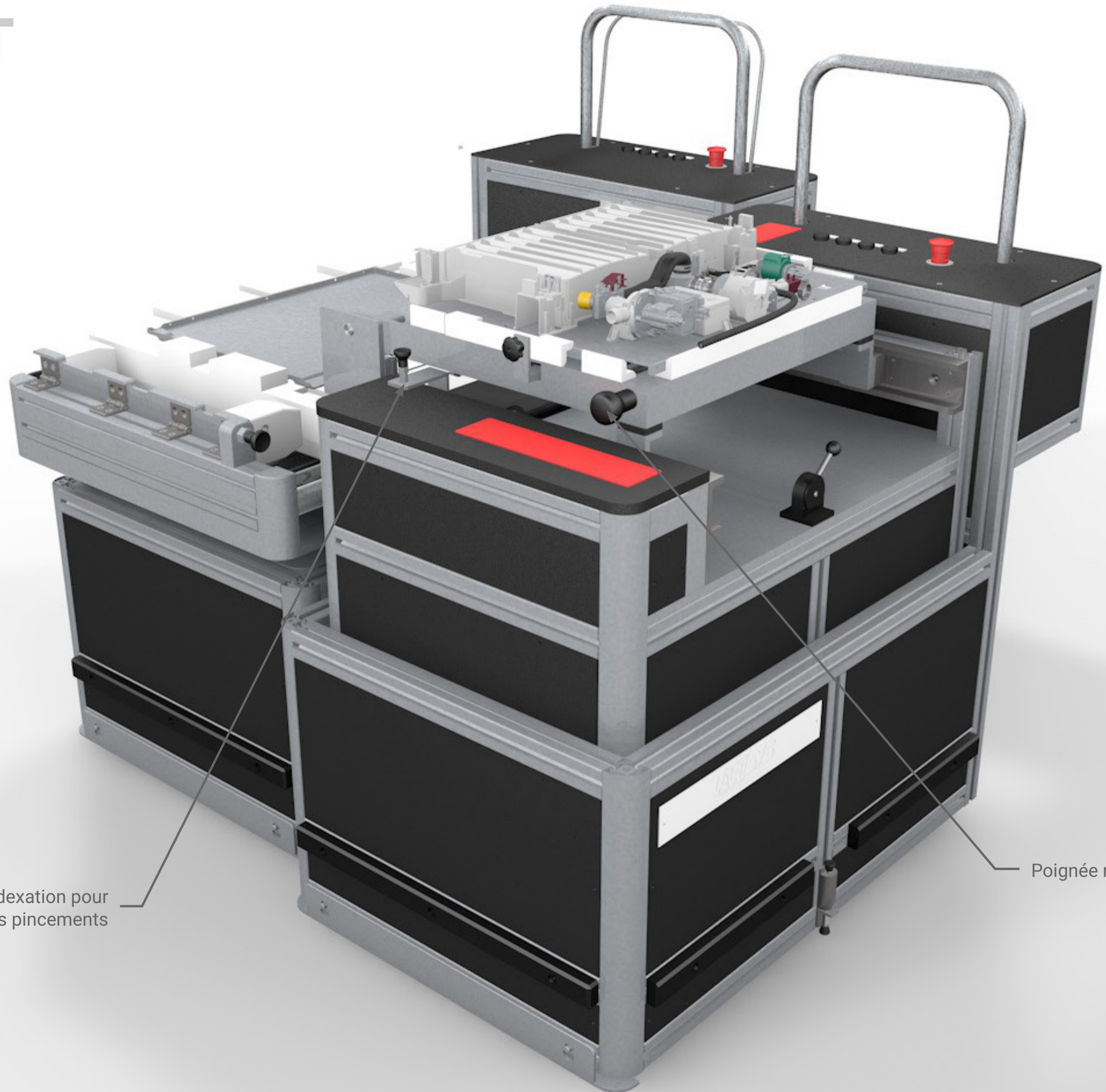

Modification du système d'indexation pour éviter les pincements

Poignée rotative

CONCEPT

Ajout de ressorts sur le système de maintien

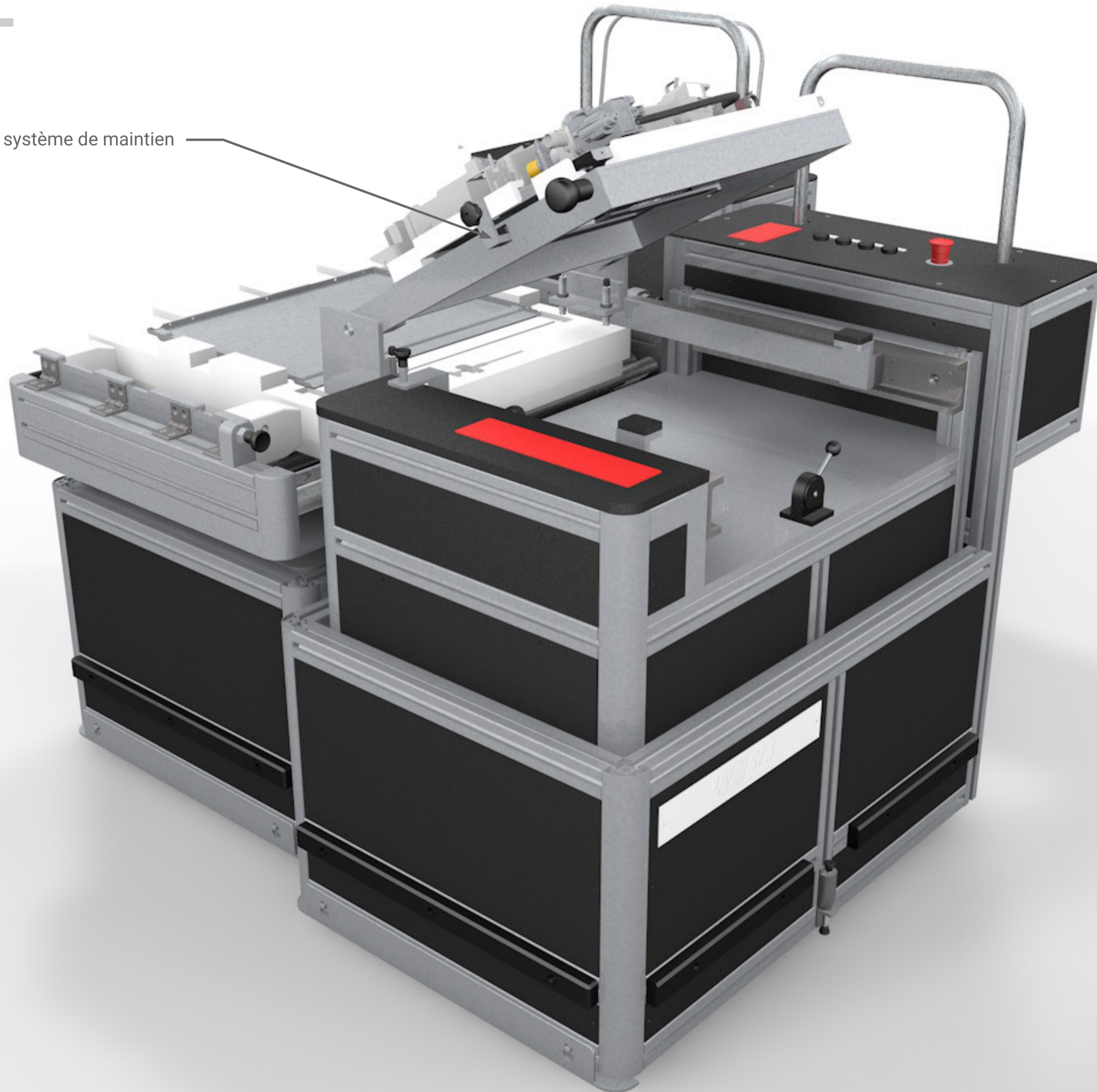

CONCEPT



